

SCRIVANIA 120x50 GIREVOLE

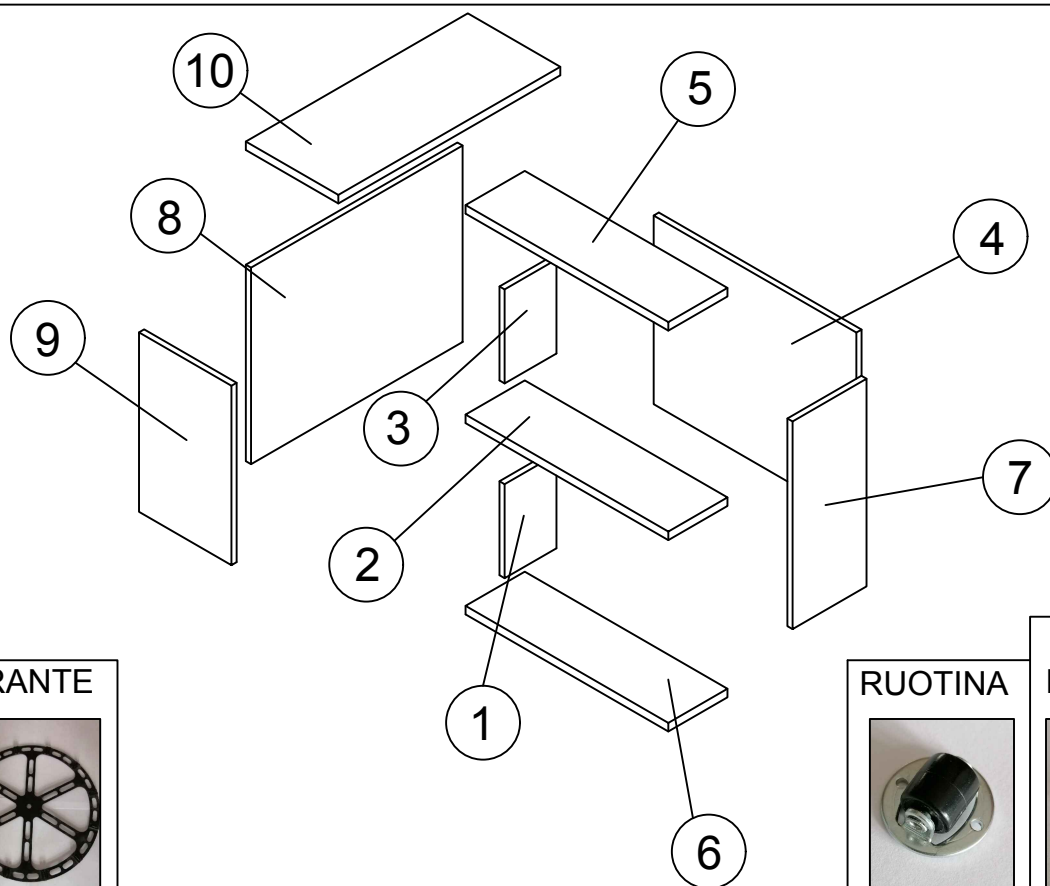

GIRANTE



GIR

RUOTINA



RUO

VITE
RUOTINA



VR

SPINOTTO



SP

GRANO



GR

PIEDINO



PI

BARILOTTO



BAR

TIRANTE



TIR

VITE M6x35



M6

BOCCOLA



BOC

MONTAGGIO BARILOTTO TIRANTE GRANO

INSERIRE IL BARILOTTO NELL'APPOSITO FORO DI DIAMETRO 14 FINO A BATTUTA, ASSICURANDOSI CHE L'ASSE DEL FORO DI DIAMETRO 8 SIA COINCIDENTE CON L'ASSE DEL FORO SUL PANNELLO IN CUI ANDRA' INSERITO IL TIRANTE.

AVVITARE IL TIRANTE NELL'APPOSITA BUSSOLA FINO A BATTUTA. ASSICURARSI CHE L'ASSE DEL SUO FORO DI DIAMETRO 3.5 SIA COINCIDENTE CON L'ASSE DEL FORO FILETTATO DEL BARILOTTO COME IN FIGURA. TALE ALLINEAMENTO SI PUO' TROVARE SVITANDO IL TIRANTE (DOPO AVERLO AVVITATO FINO A BATTUTA) FINO ALL'ALLINEAMENTO.

INFINE SI PUO' AVVITARE IL GRANO NEL BARILOTTO FINO A BATTUTA.

MONTAGGIO BAR-TIR-GR



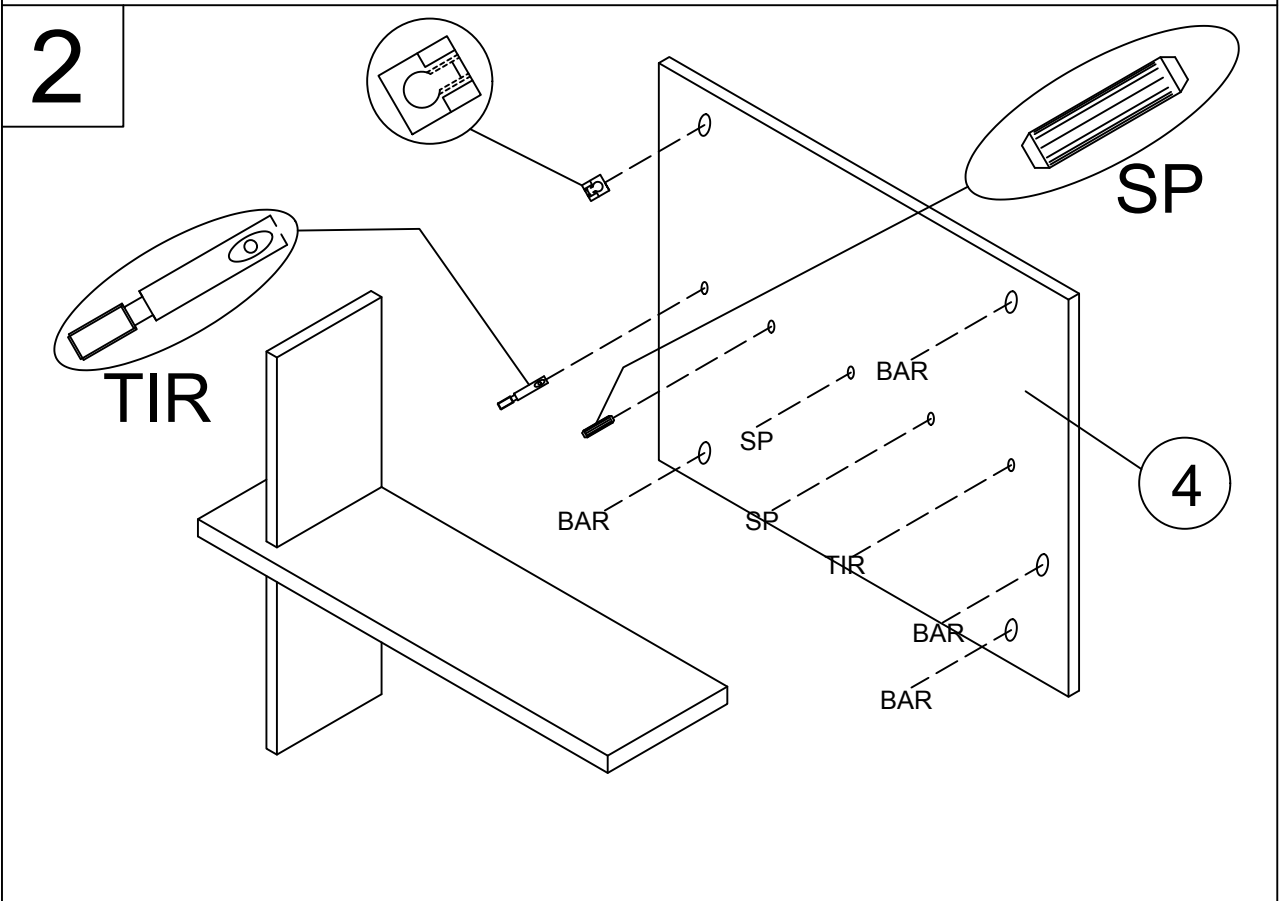
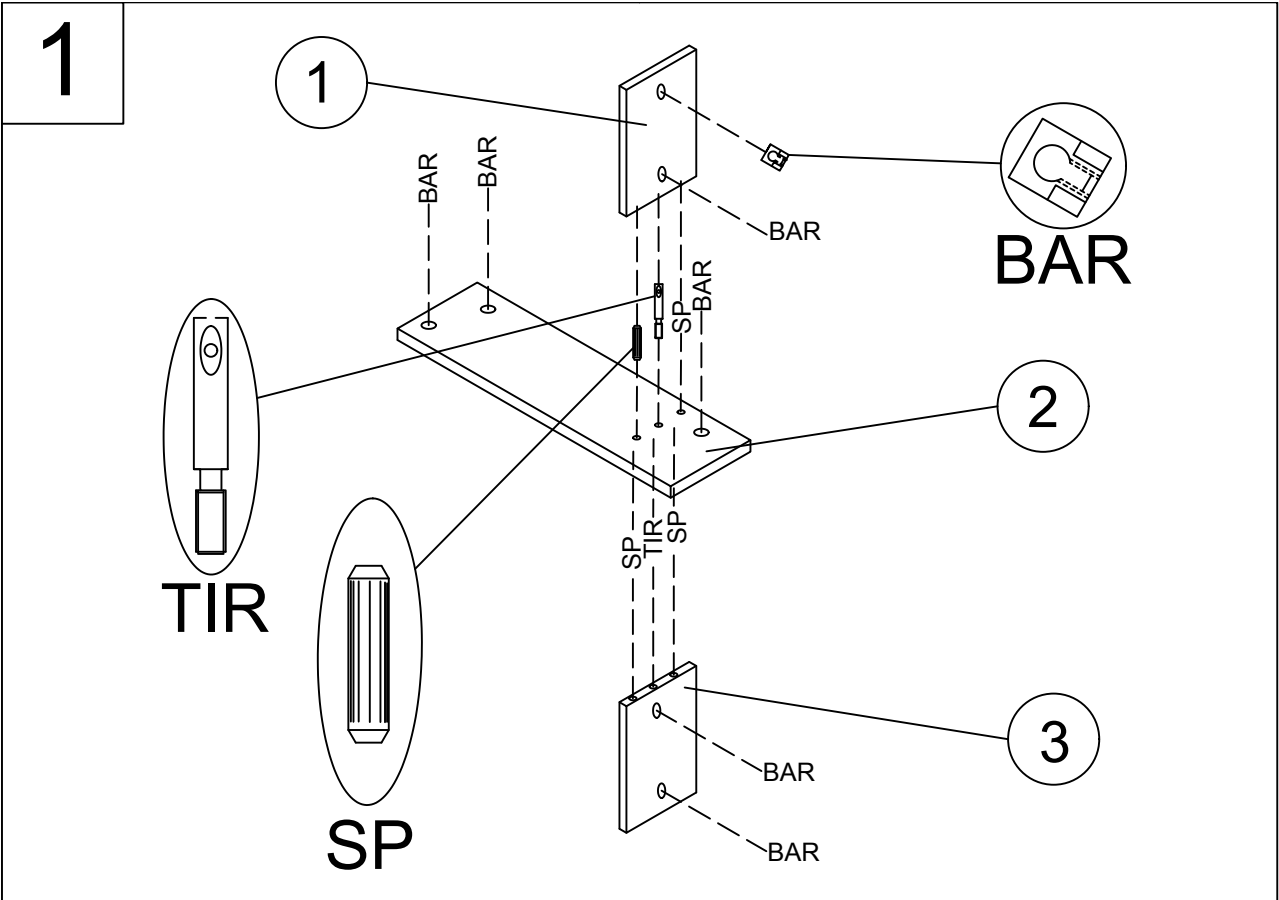

SCRIVANIA 120x50 GIREVOLE

3

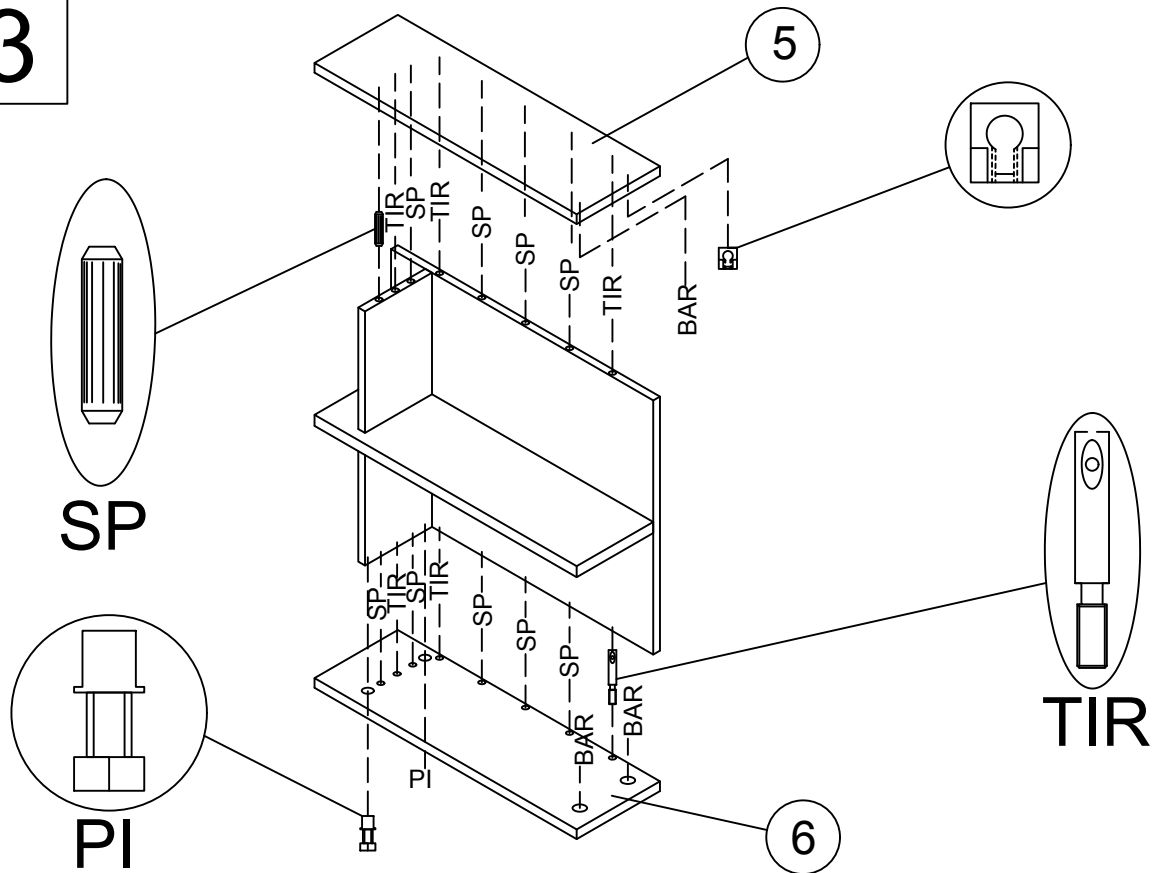

4

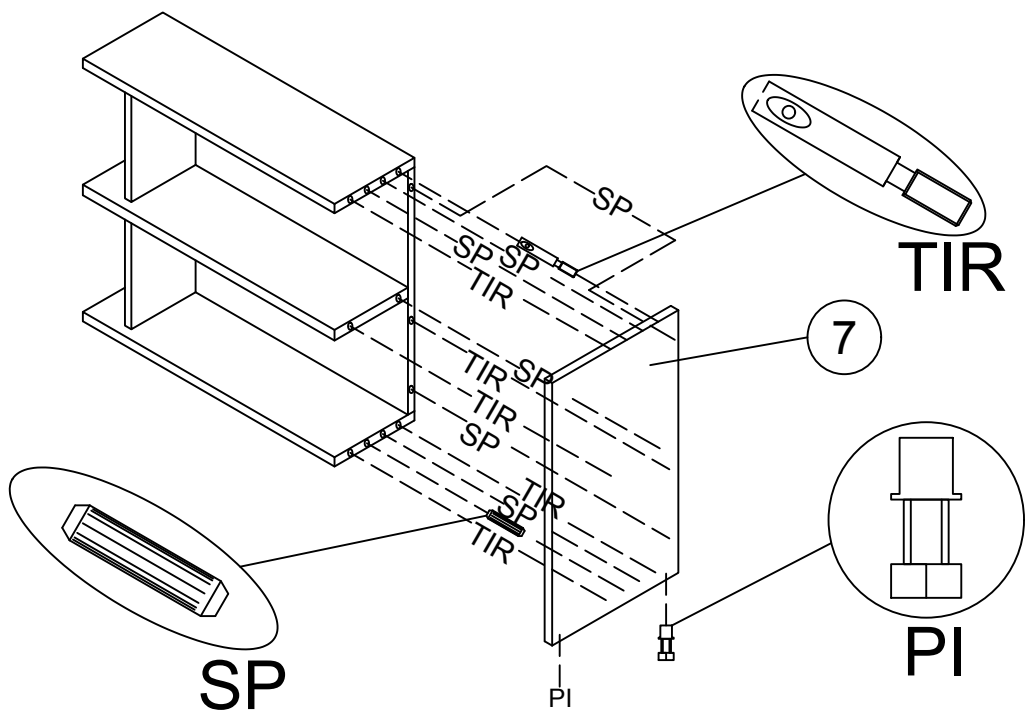

5

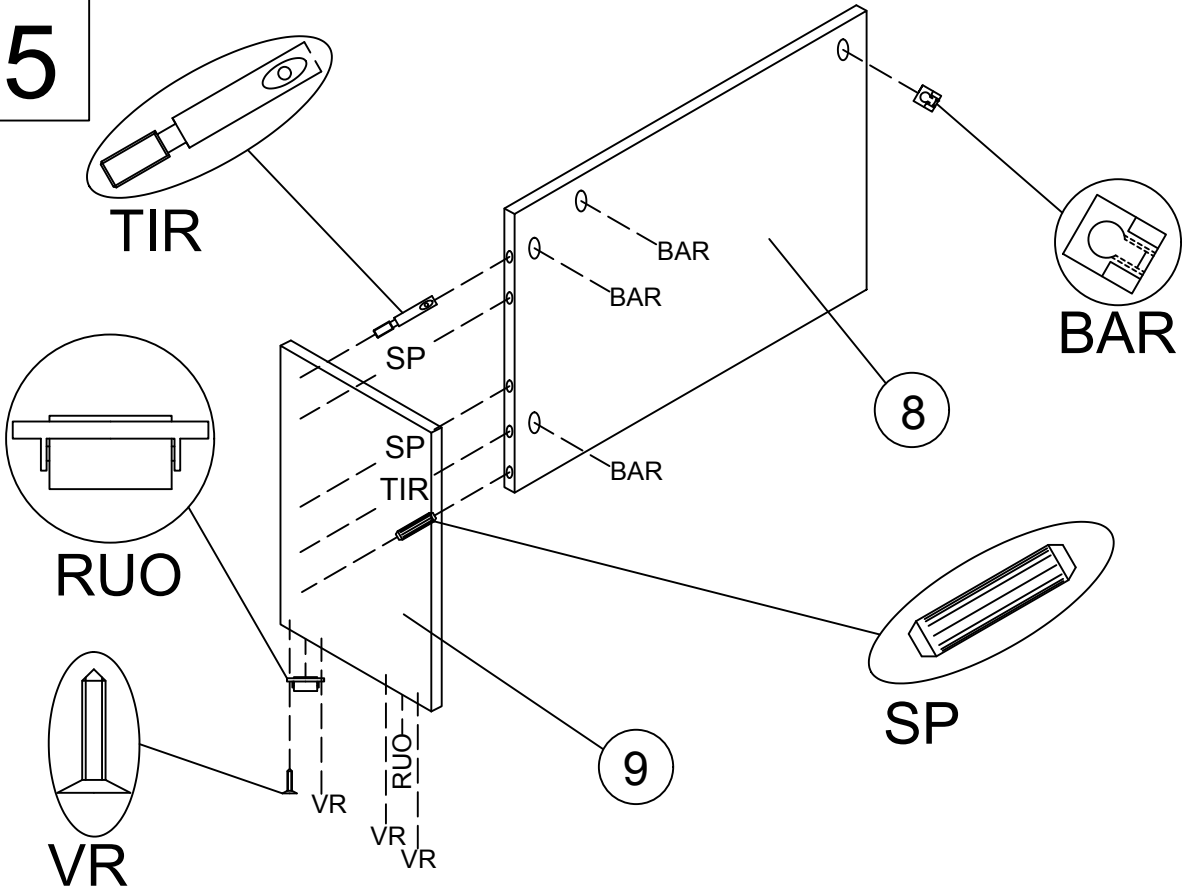

6

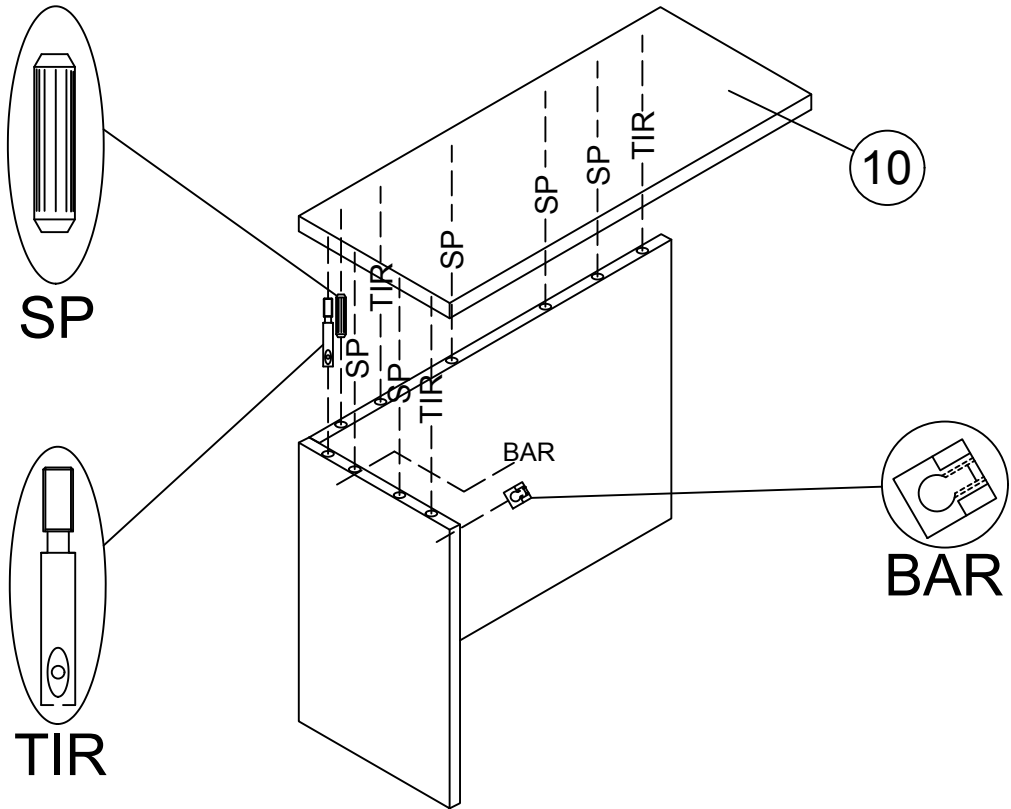

SCRIVANIA 120x50 GIREVOLE

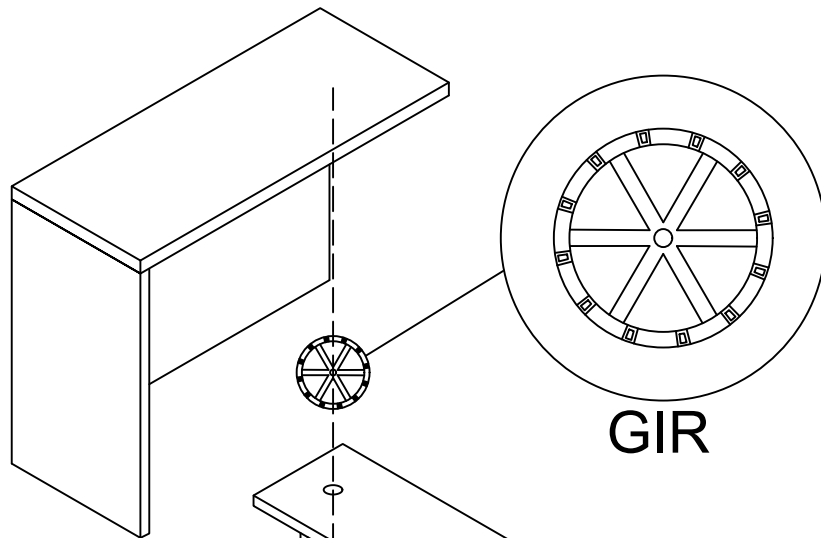

GIR

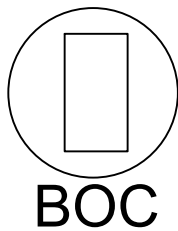

BOC

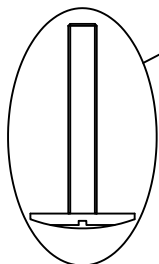

M6

BOC

GIR

M6

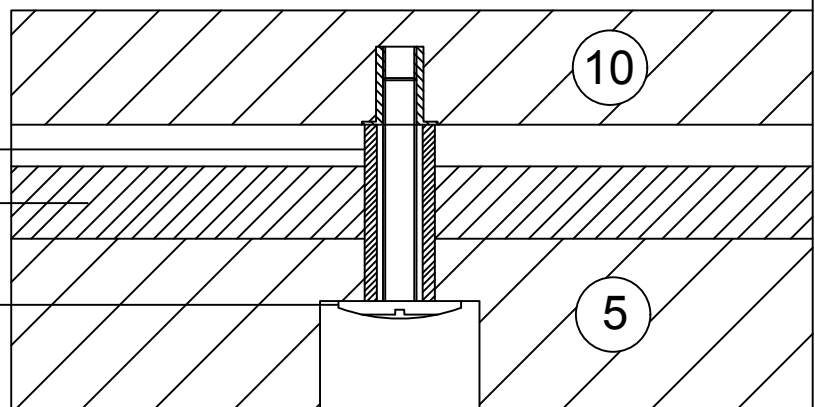

INSERIRE LA BOCCOLA NEL PIANO SUPERIORE(N°5).
INSERIRE LA GIRANTE E AVVITARE FINO A BATTUTA
IN MODO CHE TRA IL PIANO N°5 E IL PIANO N°10 CI
SIANO 6mm